



Flashblend Powder/Liquid Mixers

Capacity

Powder incorporation rates up to 15,000 kg/hr.

Materials of Construction

All product contact parts are constructed in 316 stainless steel.

Motor Specification

TEFV and ATEX approved Flameproof motors are available as standard. Stainless steel motors are available as optional extras.

Cleaning

The Flashblend is designed to be Cleaned-In-Place (CIP) with Sterilise-In-Place (SIP) as an optional extra.

Electrical

Integral stainless steel control panel.

Sealing

Single mechanical shaft seals as standard. Double mechanical shaft seals and specialised arrangements are optional extras.

Flashblend Powder/Liquid Mixers

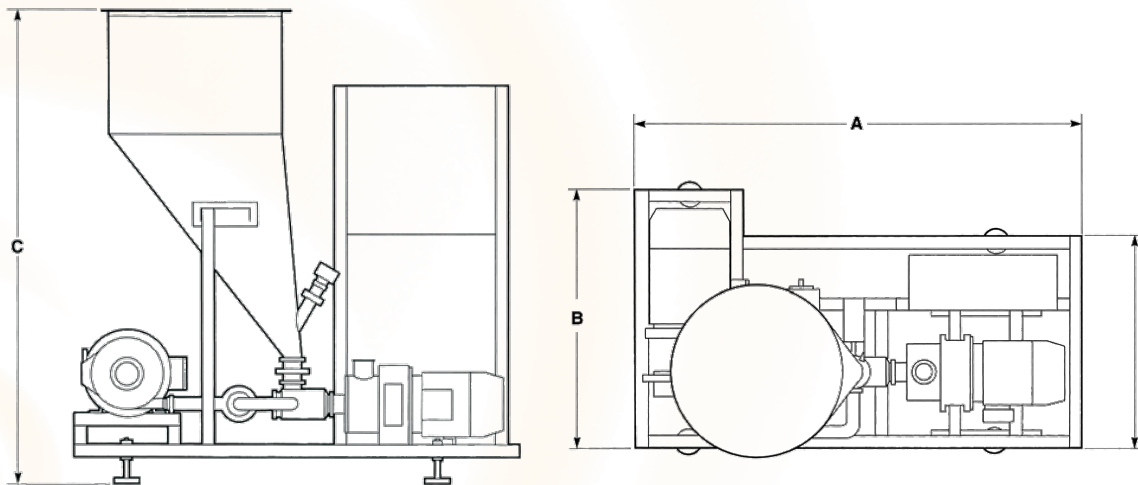

Model	A	B	C	Total Power kW	Typical Powder Flow Rate (kg/hr)	Standard Hopper Volume (litres)
FLB 20	985	645	1450	5.5	900	10
FLB 30	1520	1000	1330	8.5	3000	100
FLB 60	2000	1025	1900	26	15,000	300

* Powder flow rates are dependent on product characteristics.
 All dimensions shown are in millimetres. The dimensions shown are approximate and certified diagrams should be used for installation purposes.
 Silverson Machines reserves the right to change dimensions and specifications without notice.